

# MCP3002

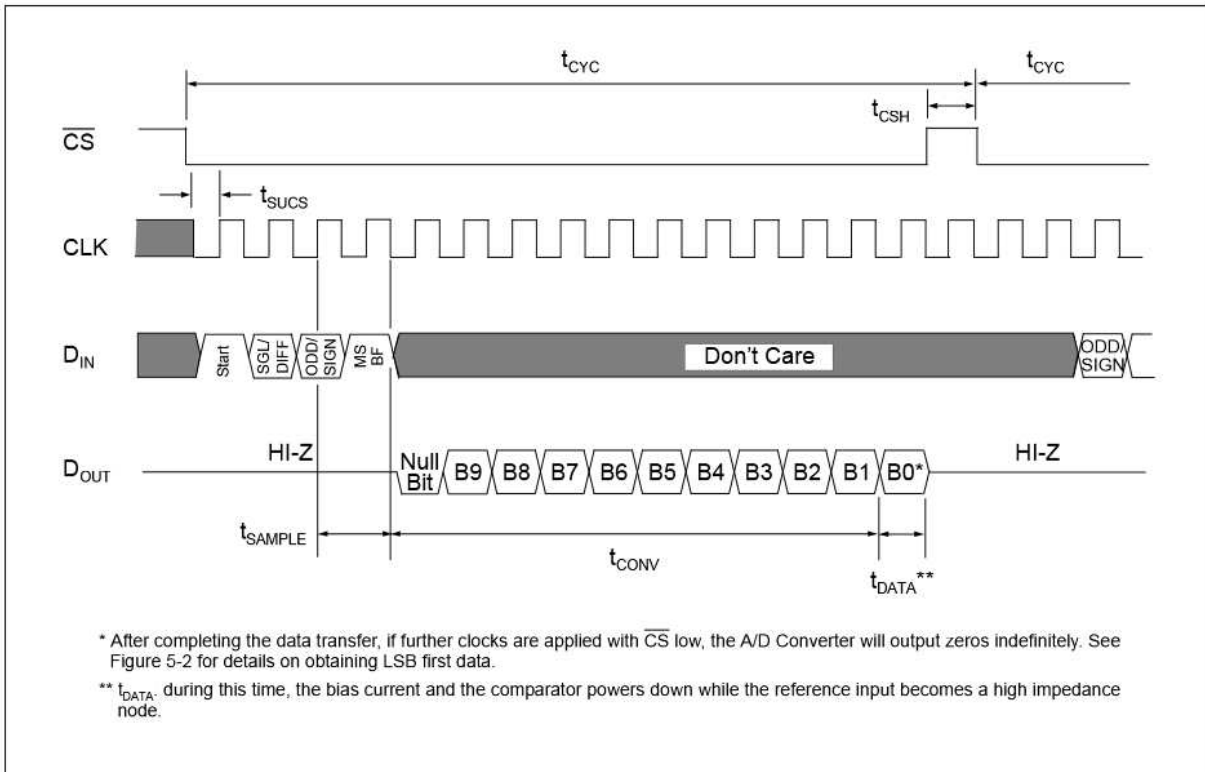

FIGURE 5-1: Communication with the MCP3002 using MSB first format only.

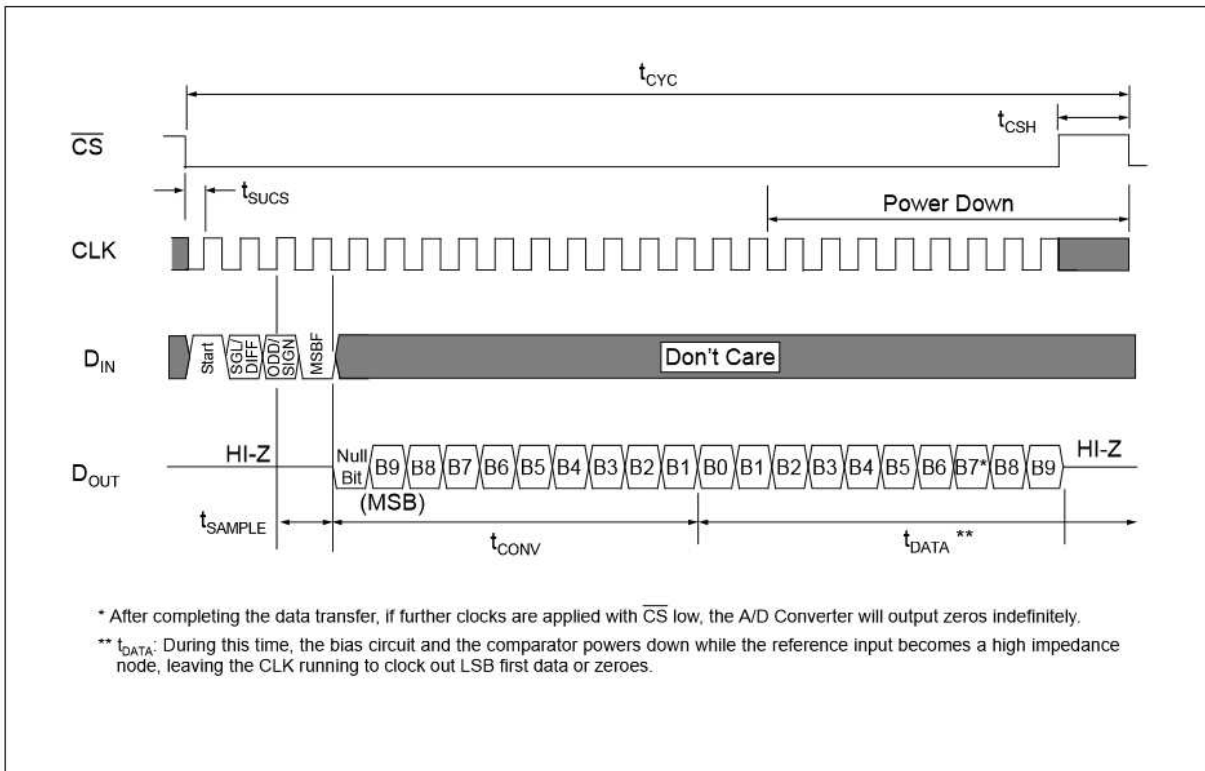

FIGURE 5-2: Communication with MCP3002 using LSB first format.